

NedValve

Compact series of electric actuators in basic or smart model



NedValve actuators are designed from a demand for compact, light weight drives with excellent mechanical and electrical specifications. NedValve electric actuators are known for its reliability and smooth control of butterfly valves and ball valves. NedValve actuators are equipped with visual position indication on top and manual override, by default.

NedValve is available in different models, basic and smart. The smart version is equipped with an OLED digital display, allowing to set runtime and alter other setting such as rotation, alarms, etc.

Below mentioned 5 different models are available:

Type	Speed	Model	Runtime
STB	default	Basic	10 - 12 sec.
QS	Quick	Smart	1 - 5 sec.
QB	Quick	Basic	1 - 5 sec.
SLS	Slow	Smart	180 sec.
CS	Control	Smart	50 sec.

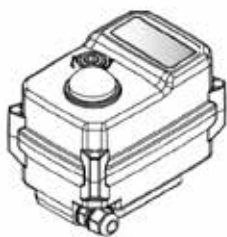

Basic model



Smart model (digital display)

NedValve can be delivered with a PowerQuick adapter for the driveshaft, fitting the ball valve of butterfly valve with ISO-top

CHARACTERISTICS

- ✓ Complete portfolio of 5 different types of NedValve actuators
- ✓ Short runtime (from 1 sec)
- ✓ Small, compact and light weight actuators
- ✓ Manual override
- ✓ 2 mechanic end switches or encoders
- ✓ Anti-condense heating
- ✓ Thermostat (25°C)
- ✓ Position indication / optional feedback
- ✓ ISO-top connection
- ✓ 0,8 mtr or 7,0 mtr cable or wirebox
- ✓ IP67 protection
- ✓ ISO 9001, CE norm
- ✓ Multi voltage actuator 24VAC - 24VDC, 50/60 Hz

APPLICATION

Electric actuators are mainly applied to control ball valves and butterfly valves in automated irrigation- or other water systems

TECHNICAL DATA

Current	: 24 V DC/AC, 50-60 Hz (QS15 / QB20 single 24VDC)
Power	: see table
Output	: 4-20 mA (24 VDC power supply) Digital end switch
Torque	: 15 tot 200 Nm (see table)
Power	: 15 tot 100 W (see table)
Temperature	: -20° tot +60°C
Humidity	: 5% tot 95%
Material	: ABS polymer (housing)
Wiring	: 0,8 mtr (basic) & 7,0 mtr (smart) or wirebox
End switch load	: 0,1A / 250VAC 0,5A/30VDC
Protection class	: IP67
Norm	: CE / RoHS / Reach / ISO9001
Wirebox connections	: 2x M20

TECHNICAL SPECIFICATIONS

Mechanical properties

Runtime	Model	Torque (NM)	Speed (sec/ °90)	Weight (kg)	Drive shaft (mm)	Assembly (ISO)
Basic	STB20	20	10	0,8	14	F03/F05*
	STB50	50	12	1,8	14	F05/F07
	STB80	80	10	2,2	17	F05/F07
	STB110	110	10	2,2	17	F05/F07
	STB200	200	25	5,0	22	F07/F10
Quick	QS15	15	1-5	0,8	14	F03/F05*
	QB20	20	1	0,8	14	F03/F05*
	QB50	50	5	1,8	17	F05/F07
	QB80	80	5	2,2	17	F05/F07
	QB110	110	5	2,2	17	F07/F10
Slow	SLS110	110	130	2,2	17	F07/F10
	SLS200	200	130	5,0	22	F07/F10
Control	CS15	15	45	0,8	14	F03/F05*

* Basic assembly F03/F05 is also available for 45° angle

Electrical properties

Runtime	Model	Voltage	Power (W)	Idle power (W)	Heater (W)	Inrush current (A)	Fuse current (A)	Feedback	Wiring
Basic	STB20	24VAC/DC	15	2,0	2,0	0,94	2	End switch	0,8 mtr 7x0,3mm ²
	STB50	24VAC/DC	25	2,0	2,0	1,56	2 / 4*	End switch	0,8 mtr 7x0,5mm ²
	STB80	24VAC/DC	60	2,0	2,0	3,75	5	End switch	Wirebox
	STB110	24VAC/DC	100	2,0	2,0	6,25	5	End switch	Wirebox
	STB200	24VAC/DC	50	2,0	2,0	3,13	5	End switch	Wirebox
Quick	QS15	24VDC	85	2,1	2,0	5,30	5	Encoder	7 mtr 7x0,3mm ²
	QB20	24VDC	85	2,0	2,0	5,30	5	End switch	7 mtr 7x0,3mm ²
	QB50	24VAC/DC	40	2,0	2,0	2,50	2 / 4*	End switch	0,8 mtr 7x0,5mm ²
	QB80	24VAC/DC	60	2,0	2,0	3,75	5	End switch	Wirebox
	QB110	24VAC/DC	100	2,0	2,0	6,25	5	End switch	Wirebox
Slow	SLS110	24VAC/DC	40	2,0	2,0	2,50	2 / 4*	Encoder	Wirebox
	SLS200	24VAC/DC	50	2,0	2,0	3,13	5	Encoder	Wirebox
Control	CS15	24VAC/DC	15	2,1	2,0	0,94	2	Encoder	7,0 mtr 7x0,3mm ²

* depending on voltage: 24VAC of DC

Models

Series 15 / 20



Series 50



Series 80 / 110



Series 200



DIMENSIONS

Series 15 / 20

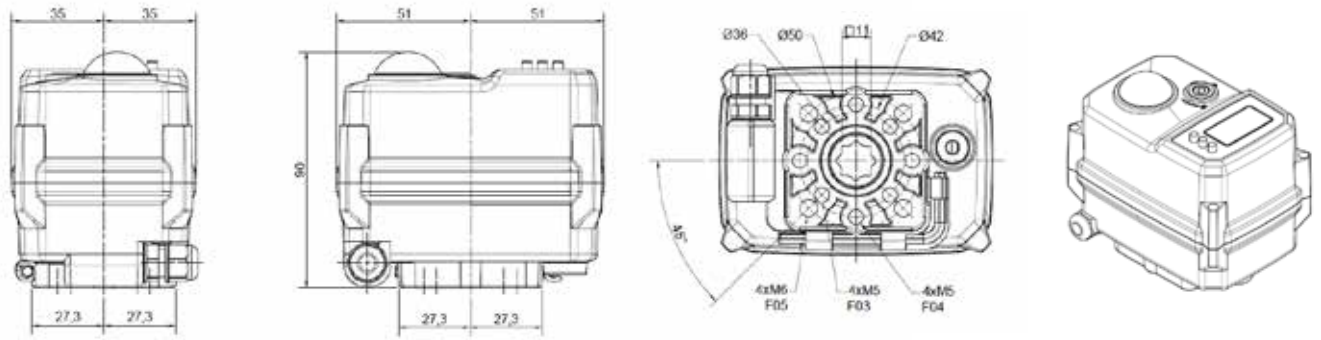

Series 50

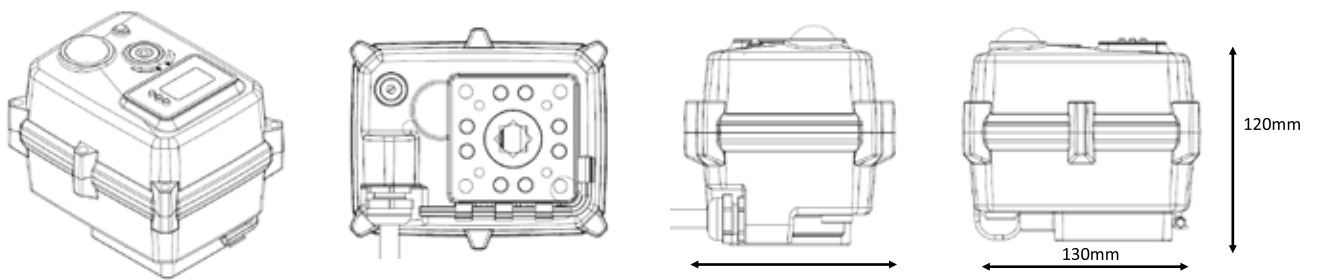

Series 80 / 110

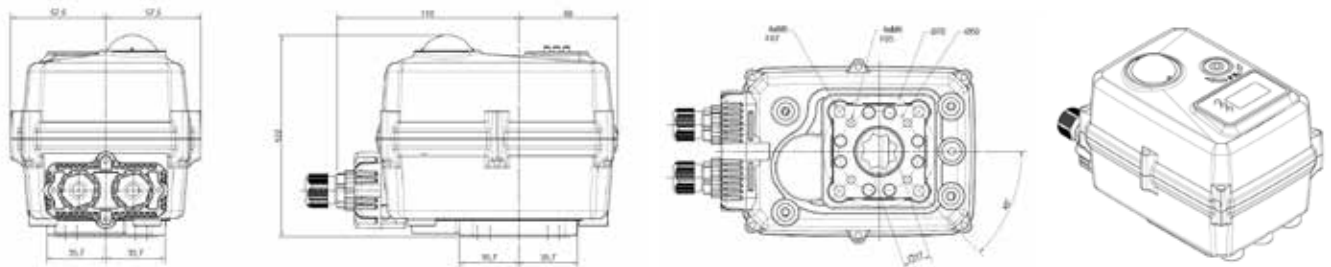

Series 200

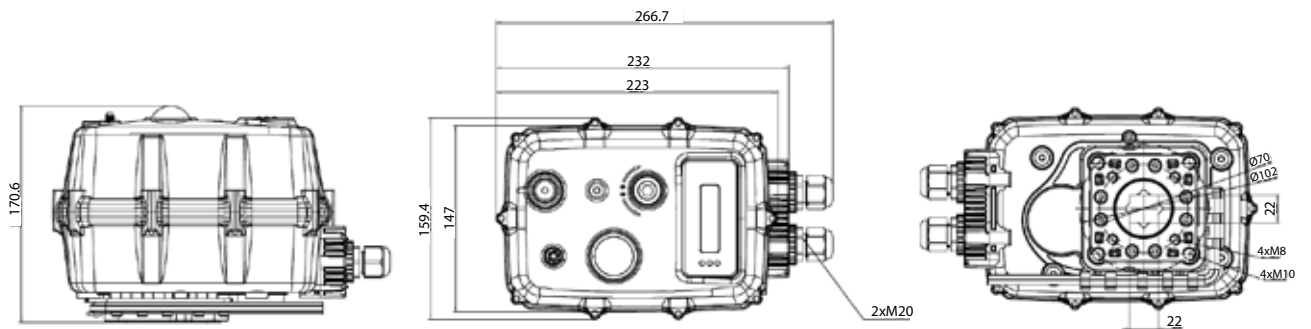

SCHEMATICS AND WIRING

Basic motor (B3S)

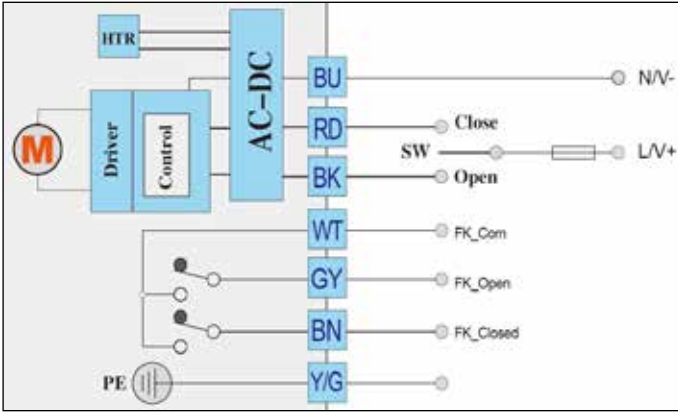

Smart motor with digital feedback (B3J)

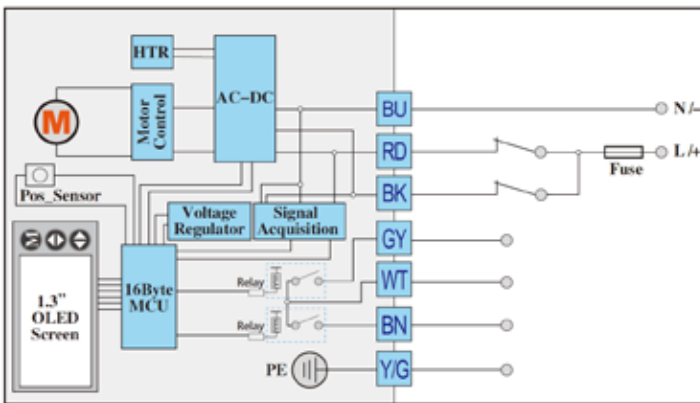

Smart motor with analogue feedback (B3 4-20mA)

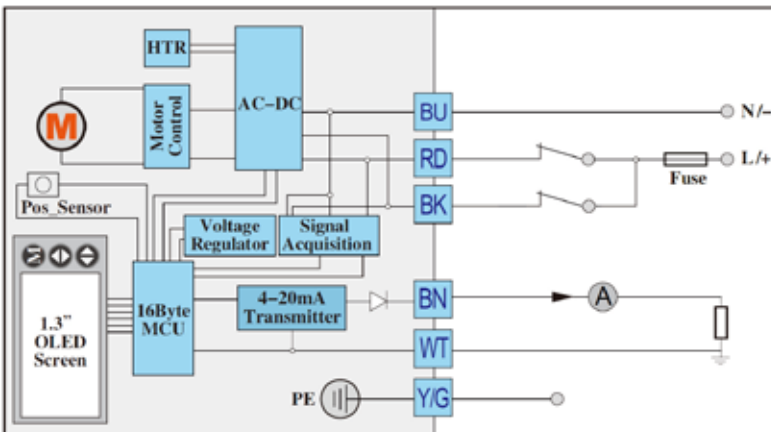

Wiring and wirebox

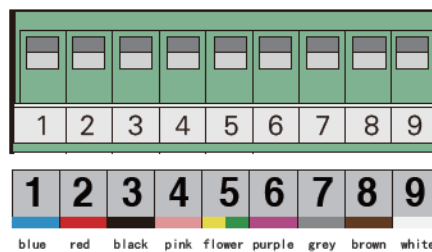
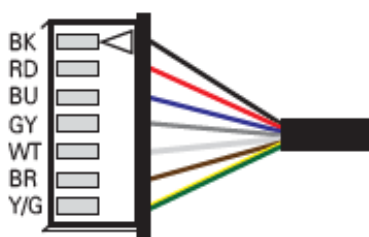

Smart model with Local Control

All smart actuators are supplied with Local Control allowing for local control using 3 display keys. Local control is used to alter settings and to control manually.

Advantages of smart model

Compared to the basic model the smart model has the following extra specifications:

- ✓ 1,3" OLED colour display
- ✓ Several to be altered settings: speed, runtime, position offsets, dead zone, control angle (for 3-way valves), multi turn, etc.
- ✓ Encoder in stead of end switches (with relays)
- ✓ Extra long wiring (Series 15)

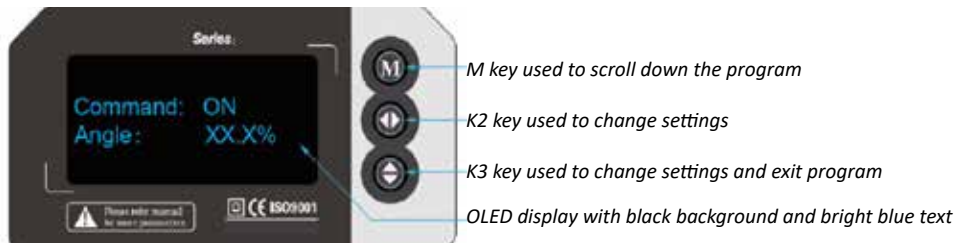

INSTALLATION & MAINTENANCE

Installation

- ✓ Quick guide manual inside, please read carefully before installation
- ✓ NedValve actuators are multi voltage, except model QS15 and model QB20 (DC only).
- ✓ In case of a 4–20 mA output, the actuator must be powered/controlled with 24 VDC.
- ✓ Use proper wiring according to local rules and regulations.
- ✓ Do not install NedValve in an EX sensitive area
- ✓ Series 15, 20 & 50 are equipped with fixed wiring.
- ✓ Series 80, 110 & 200 are equipped with a wiring box.
- ✓ Always use proper Protection Earth connection.
- ✓ Despite the IP67 protection class, it is sensible to protect the NedValve against weather influences when mounted outside.
- ✓ Please note: by opening the top cover the manufacturer's warranty will be expired. The internal NedValve contains no replaceable parts (such as glass fuses).

Maintenance

- ✓ Always switch off power before commencing maintenance

